

Schedule 8 Approved Drug Safes Australia-Wide



- Pharmacies
- Hospitals
- Ambulance Stations
- Medical Centres
- Veterinarians
- Aged Care Facilities

Our complete range of Drug Safes meet all Australian State and Territory Regulations for the storage of S8 Drugs. Unsure of your State Regulations and Requirements? Call us today 1800 080 280 for more details.

DSK Drug Safes

The DSK Range is the most popular and cost effective Schedule 8 drug safe. Available with either a Key or a Commercial Grade UL Digital Lock, the DSK Range is ideal for use in Hospitals, Medical Centres, Pharmacies, Aged Care Facilities, & Veterinary Clinics.

KS Series Drug Safes

The KS series is a premium High Security Safe suitable for use in Pharmacies in all states and territories including WA and Tasmania.

Chubb DC Drug Cabinets

The DC Drug Cabinet is a basic Schedule 8 approved drug safe that can be wall mounted for use in Veterinary Clinics, Medical Centres, Pharmacies, and Hospitals.

The DSK safe range of drug safes is the most popular and economical drug safe to comply with current Australian State Health Department Regulations regarding the storage of schedule 8 drugs



Ideal for Pharmacies, Hospitals, Aged Care, Nursing Homes, Vets



The DSK Drug Safe is fitted with a six lever pick resistant lock to ensure compliance to the strict rules for storing drugs. The safes can also be ordered with an electronic digital lock for ease of use and audit trail to track user access and times.

Featuring pre drilled anchor holes in the rear and base, adjustable shelves and high quality durable paint the DSK range is designed for years of hard wear and tear.

Optional Locking:

- Securam Digital Lock
- Securam Digital Lock with Audit Trail
- Access Control Lock

Specifications

- 6 Lever Pick-Resistant Lock available as standard
- Anti-tamper re-locking device on lock
- Hardened anti-drill plates surrounding the lock
- Solid steel 10mm body
- Solid steel 10mm door
- Solid steel 20mm bolt-work
- External hinges with internal anti-pry dead bar.
- Australian Health Department compliant
- Durable hardened paint finish
- Adjustable Shelving
- Pre-drilled 12mm anchoring holes



**Unsure of your State Regulations and Requirements?
Call us today 1800 080 280 for more details.**

Model	External (mm)			Internal (mm)			Weight (kg)	Shelves (adj)
	Height	Width	Depth	Height	Width	Depth		
DSK1	457	305	180	437	285	115	45	3
DSK1/300	457	305	300	437	285	235	63	3
DSK2	610	457	180	590	437	115	73	4
DSK2/300	610	457	300	590	437	235	99	4
DSK3	1220	762	400	1200	742	305	325	5
DSK4	1525	762	400	1505	742	305	390	5
DSK5	920	460	300	900	440	235	139	4
DSK6	800	500	300	780	480	235	132	4

DEPTH MEASUREMENT DOES NOT INCLUDE THE HANDLE, KEYPAD OR HINGES. PLEASE ALLOW 50MM. Due to Multifile constantly striving to deliver better products; sizes and colours may vary slightly.

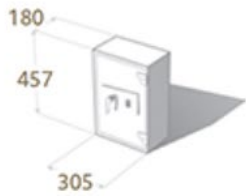

● DSK1

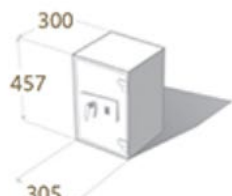

● DSK1/300

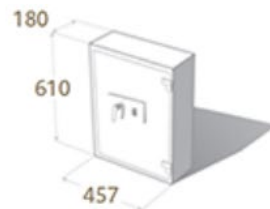

● DSK2

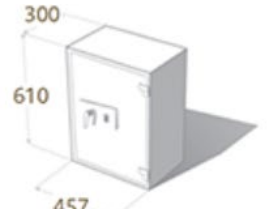

● DSK2/300

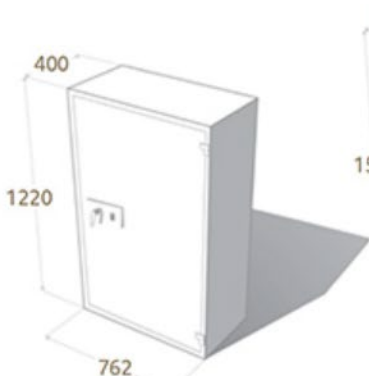

● DSK3

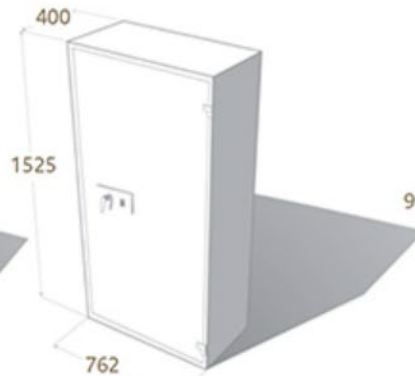

● DSK4

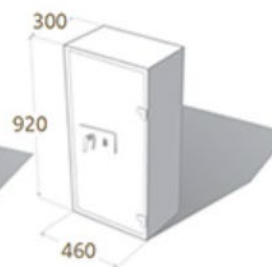

● DSK5

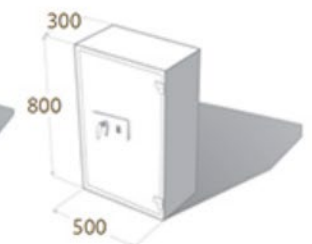

● DSK6

The Multifile KS Series is a high security range of safes with specifications that meet the more stringent Schedule 8 storage requirements of WA and TAS.



The Multifile KS series of safes is a High Security Safe. Suitable for use in Pharmacies across WA and Tasmania where min. weight and locking specifications are required. This series of safe is designed and manufactured to give a high level of resistance against professional attack.

SECURITY FEATURES:

- Commercial UL digital lock and keypad
- 6-lever pick resistant key lock
- Anti-tamper re-locking devices on both locks
- Hardened anti-drill plates surrounding both locks
- Concrete filled body
- External hinges with reinforced internal anti-pry bolts
- Solid steel 12mm door
- Solid steel 32mm bolt-work
- 60 minutes fire resistant
- Suggested \$100000 cash rating
- Durable hardened paint finish
- Adjustable Shelving
- Pre-drilled anchoring holes, 2 x 17mm diameter





**Unsure of your State Regulations and Requirements?
Call us today 1800 080 280 for more details.**

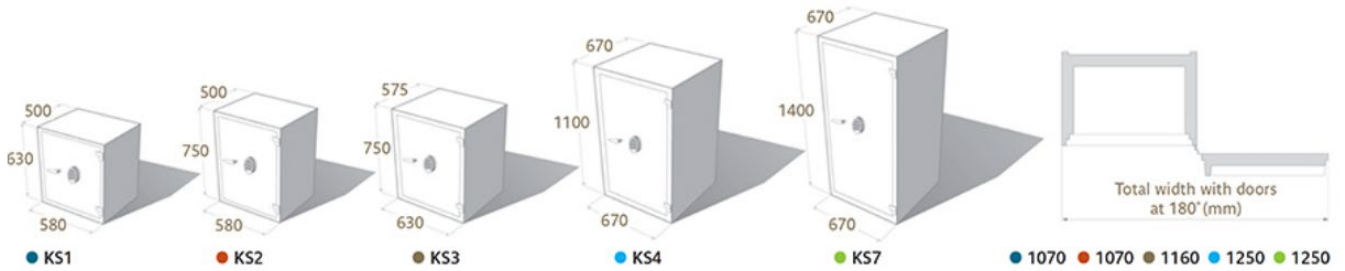

Model	External (mm)			Internal (mm)			Weight (kg)	Shelves (adj)	Cash Rating \$
	Height	Width	Depth	Height	Width	Depth			
KS1	630	580	500	500	425	325	510	2	100,000
KS2	750	580	500	620	425	325	535	3	100,000
KS3	750	630	575	620	480	415	560	3	100,000
KS4	1100	670	670	970	510	510	600	3	100,000
KS7	1400	670	670	1270	510	510	800	5	100,000

DEPTH MEASUREMENT DOES NOT INCLUDE THE HANDLE, KEYPAD OR HINGES. PLEASE ALLOW 50MM.

Due to Multifile constantly striving to deliver better products; sizes and colours may vary slightly.

The Chubb DC range of drug safes for basic storage of Schedule 8 drugs



Description

Burglary resistant drug cabinet for hospitals, doctor's surgeries and pharmacies. Schedule 8.

DOOR & BODY: The Drug Cabinet is made from 10mm thick steel.

INTERIOR FITTINGS SHELF:

The DC1 Model comes with 3 internal shelves

The DC2 Model comes with 4 internal shelves

Key Features

- Suitable for storage of prescription drugs
- Ideal for hospitals, doctor's surgeries, pharmacies or any other situation where securing stock is required
- Supplied with key lock
- Constructed from 10mm solid steel
- Each model is supplied with shelves
- Available in 3 sizes
- Welded strap on lock body
- Boltwork encased when retracted
- Complies with all state codes

PRODUCT SPECIFICATIONS

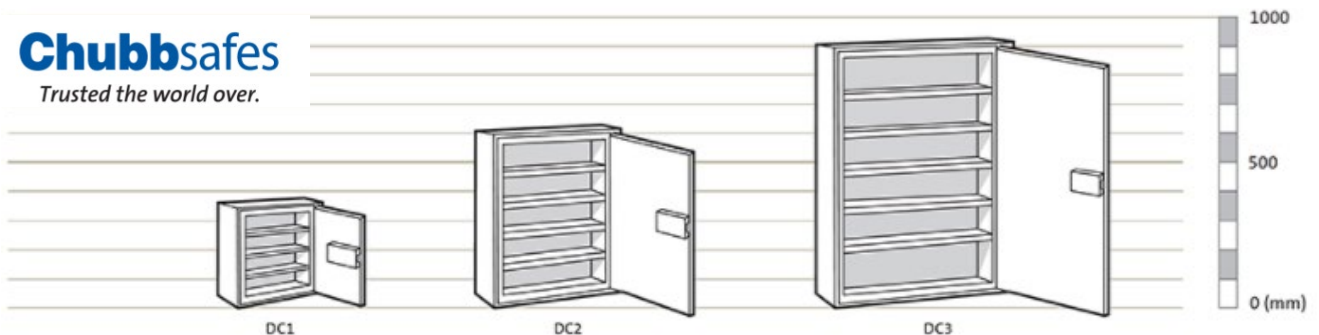

Model	Ext. Height (mm)	Ext. Width (mm)	External Depth (mm)	Int. Height (mm)	Int. Width (mm)	Int. Depth (mm)	Volume (litres)	Weight (kg)
DC1	350	240	150	330	220	130	10	27
DC2	600	450	150	580	430	130	32	66
DC3	900	600	300	880	580	260	132	160

* In electronic models, add 20mm to allow for keypad projection.